

## Installation Instructions

### 1. Preparation for Install of Surge Protection Device (SPD)



A. Verify the system voltage and wiring configuration is the same as the enclosed SPD by metering the panel voltage and checking it against the product label located on the SPD.

B. Review the installation area to ensure the proper space is available to properly mount and

install the SPD. The enclosure should be mounted no more than 3 feet away from the distribution panel.

C. Check that the buildings facility grounding system meets all NEC & CEC requirements as well as local codes. A low resistance ground system is essential to the proper functioning of any SPD. The soil resistance level should be no more than 25 ohms. This can be verified by performing a soil resistivity test.

### 2. Location of Surge Protection Device (SPD)

A. For service entrance applications, install the SPD at the main distribution panel on the load side after the main disconnect.

B. For feeder/sub-panel applications, install the SPD directly adjacent to the panelboard.

**IMPORTANT! Remember to keep conductor lead length to a maximum of 3ft or less.**

### 3. Wiring of Surge Protection Device (SPD)

A. TURN OFF the power to the distribution panel where the SPD will be installed.

*Optional: Install a circuit breaker to feed the SPD. This will allow safety personnel to remove power from the device in order to diagnose or service the unit. In addition, the device incorporates internal fusing, UL & CSA approved, that will protect against short circuit fault conditions within the unit.*

B. Nipple mount SPD, or install either a rigid or flexible metal conduit between the SPD and the distribution panel.

C. Run wires of SPD to distribution panelboard - See wiring diagrams for details.

D. Ensure proper color codes: *Table 1.*

E. Tighten and recheck all connections.

F. If remote monitoring is employed, connect the form "C" contacts to the building monitor system or independent alarm, i.e. addressable relay. Contact relays will accept up to 1A/220 VAC. The dry contact terminals are N.O. (normally open), N.C. (normally closed) and COM (common). *Diagram 1.*

NOTES: *Check wiring before applying power.*

Table 1

Wire	Color
Ground	Green or Green/Yellow
Neutral	White
Hot	Red, Blue, Black (Phase C, Hi-Leg)

Diagram 1

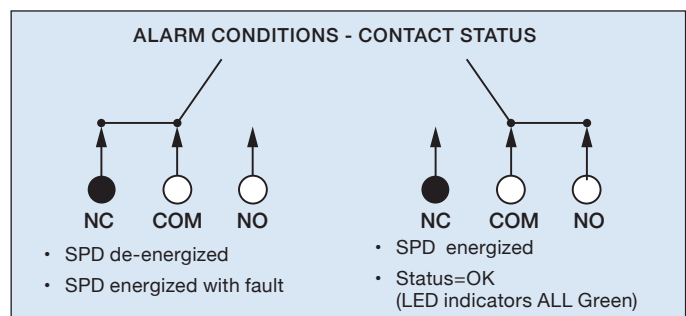

**Technical Assistance Call:**  
703-687-4507

Register Online at:  
[www.pspproducts.com](http://www.pspproducts.com)



**Important: Risk of electrical shock. This device should only be installed by qualified personnel.**

**Figure 1**

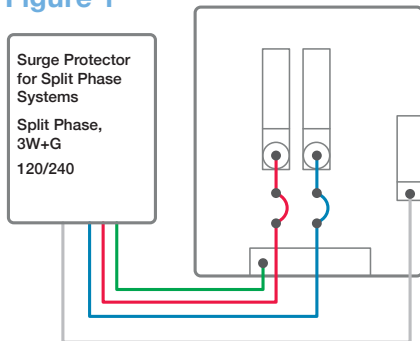

**Figure 2**

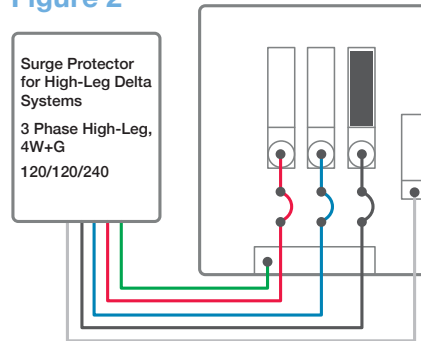

**Type 1 Disconnect Installation Diagram**

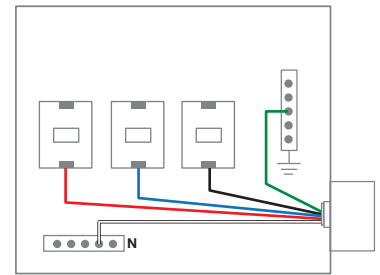

**Figure 3**

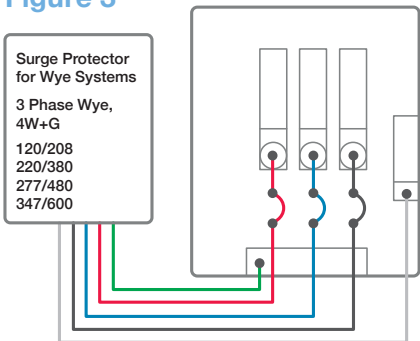

**Figure 4**

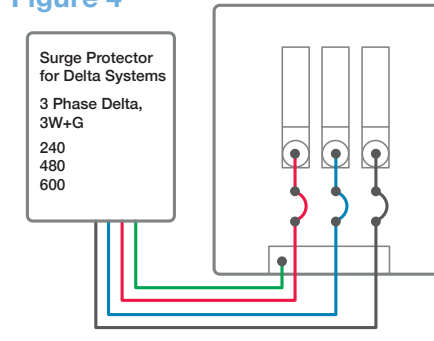

### Mounting Dimensions for NEMA 1 or NEMA 4

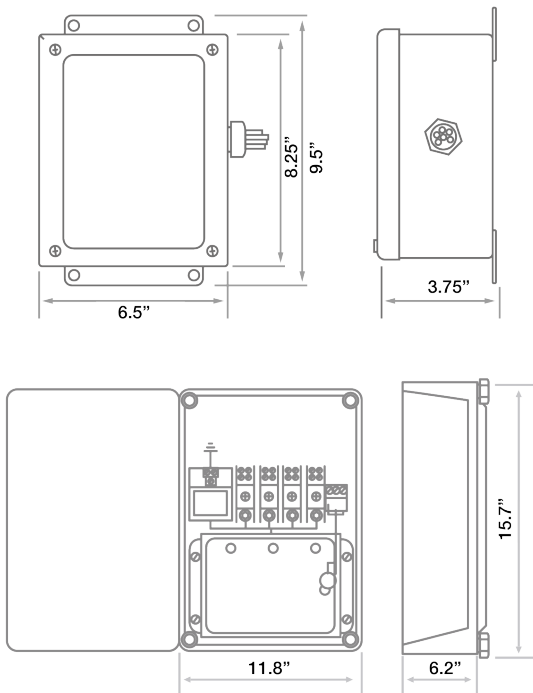

### Voltage Configuration

Voltage	Phases	Wires	Neutral	Diagram
120/240 VAC	Split Phase	3W+G	Yes	Fig. 1
120/120/240 VAC	Three Phase High-Leg Delta	4W+G	Yes	Fig. 2
120/208 VAC	Three Phase Wye	4W+G	Yes	Fig. 3
220/380 VAC	Three Phase Wye	4W+G	Yes	Fig. 3
277/480 VAC	Three Phase Wye	4W+G	Yes	Fig. 3
347/600 VAC	Three Phase Wye	4W+G	Yes	Fig. 3
240 VAC	Three Phase Delta	3W+G	No	Fig. 4
480 VAC	Three Phase Delta	3W+G	No	Fig. 4
600 VAC	Three Phase Delta	3W+G	No	Fig. 4

# Category 4 Hurricane Warranty

## PSP Product Warranty 25 Year Limited Commercial Warranty Coverage for the Category 4 Hurricane Surge Protection Device

PSP will, at its sole discretion, repair or replace any Category 4 Hurricane Commercial Surge Protection Device (SPD) that is defective or is damaged by a transient electrical spike (including those caused by lightning) for a period of twenty-five (25) years from the date of installation by the original owner or owner of record of premises.

### Exclusions

The above coverage applies to the original end user purchaser only and is the exclusive remedy under this warranty, whether based in contract, tort, including negligence, or otherwise. Claims must be made within 30 days of damage. This warranty does not cover damage associated with sustained over voltages, vandalism, theft, normal wear and tear, obsolescence, abuse, unauthorized modification or alteration, misuse, improper installation or catastrophic events.

PSP Products disclaims liability for any incidental, indirect, special or consequential damages arising out of the sale or use of any PSP products (including, without limitation, lost business profits, loss of data and all freight, mileage, travel time and insurance charges associated with warranty coverage claims).

Some states do not allow the exclusion or limitation of incidental or consequential damages, so the above limitation or exclusions may not apply to you. This warranty gives you specific legal rights and you may have other rights which vary from state to state. *This warranty is valid in the United States and Canada only.*

### Claim Procedure

1. Contact PSP Products at 1-703-687-4057 to obtain a Return Authorization (RA) number.
2. Return PSP device to PSP Products, freight prepaid.
3. PSP Products returns working device, freight prepaid.

**Caution: Effective surge suppression requires correct wiring. All surge protection devices must be properly grounded for the warranty to be honored.**



**Warranty Assistance Call 703-687-4057**  
PSP Products, 8618 Phoenix Drive, Manassas VA 20110  
Register Online at: [www.pspproducts.com](http://www.pspproducts.com)