

Installation Instructions

1. To assure proper installation measure the voltage on each phase and insure the correct device is installed.
2. Turn off power to circuit where surge protector is to be installed.
3. Mount device so as to keep conductor length as short as possible. Cut wires to shortest functional length and connect to circuit per wiring diagram (avoiding sharp bends or looping).
4. Reinstall covers, restore power and confirm diagnostic LED is illuminated.

Diagnostic Operation

- LED ON = Normal operation
- LED OFF = Fault, check voltage & connections. If OK, replace unit.

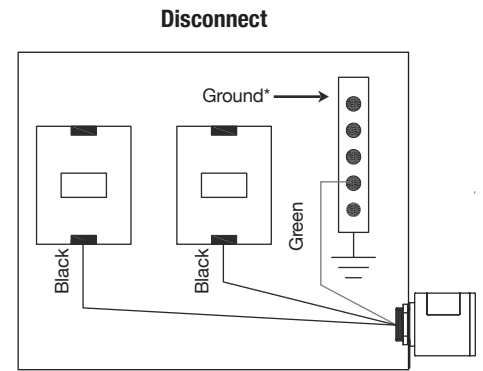
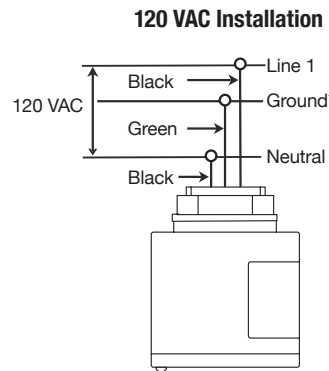
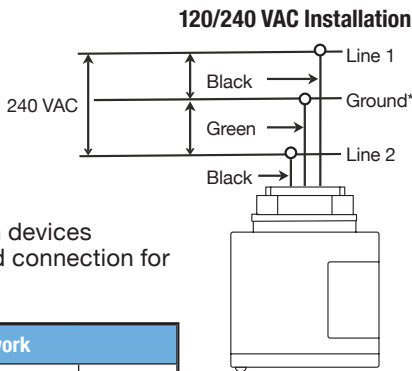

*All surge protection devices require good ground connection for effective operation

AC Network	
Nominal Voltage	120VAC
Max. Operating Voltage (MCOV)	150VAC
Max. Discharge Current (Imax)	50kA

Technical Assistance Call: 703-687-4057

PSP Products Inc. | 8618 Phoenix Drive, Manassas, VA 20110
pspproducts.com | 703.687.4057 | sales@pspproducts.com

Installation Instructions

1. To assure proper installation measure the voltage on each phase and insure the correct device is installed.
2. Turn off power to circuit where surge protector is to be installed.
3. Mount device so as to keep conductor length as short as possible. Cut wires to shortest functional length and connect to circuit per wiring diagram (avoiding sharp bends or looping).
4. Reinstall covers, restore power and confirm diagnostic LED is illuminated.

Diagnostic Operation

- LED ON = Normal operation
- LED OFF = Fault, check voltage & connections. If OK, replace unit.

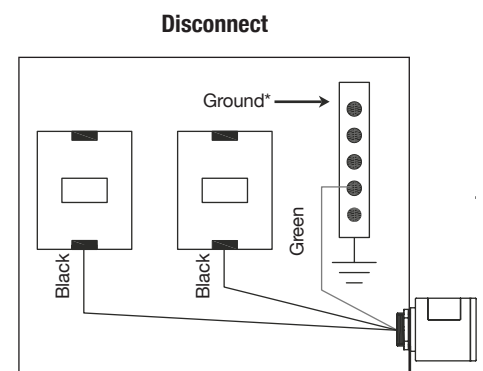
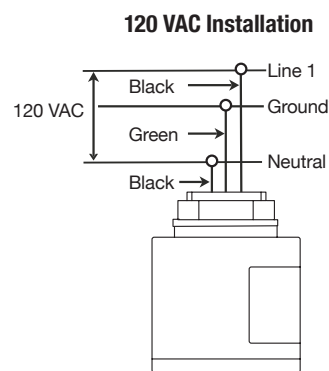
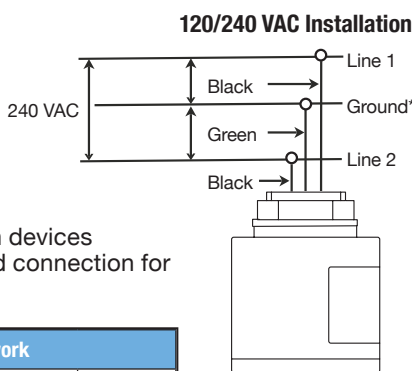

*All surge protection devices require good ground connection for effective operation

AC Network	
Nominal Voltage	120VAC
Max. Operating Voltage (MCOV)	150VAC
Max. Discharge Current (Imax)	50kA

Technical Assistance Call: 703-687-4057

PSP Products | 8618 Phoenix Drive, Manassas, VA 20110
pspproducts.com | 703.687.4057 | sales@pspproducts.com

VA1-50-4XP Product Warranty

Lifetime Product Coverage

PSP will, at its sole discretion, repair or replace any VA1-50-4XP Surge Protection Device (SPD) that is defective or is damaged by a transient electrical spike (including those caused by distant lightning) for the lifetime of the product from the date of installation by the original owner or owner of record of premises.

Down Line Coverage

PSP Products will repair or replace (whichever is less) electrical appliances and electronics that are damaged as a result of a transient surge* greater than the capacity of the SPD, originating at the main utility service entrance. Maximum lifetime coverage per household: \$25,000. Coverage is applicable only if the service entrance SPD (1) was fully functional immediately prior to the claim event, and properly installed per the installation instructions and to NEC guidelines and (2) the SPD received a transient surge greater than its capacity as indicated by the diagnostic LEDs.

External items that are mounted outside of the house are covered under this warranty only if the surge is found to have originated from the main circuit panel due to Service Entrance SPD at end of life, as indicated by diagnostic LEDs. This provision is stated because all exterior wiring is vulnerable to surges caused by nearby lightning strikes. To best protect your exterior items, additional surge protection devices installed at the unit are highly recommended.

Any electronic devices that are connected to phone lines, data lines, coax connections, cable, antennas, satellite receivers, internet, or any other external connections must have a surge protection device for each of the external signals connected to the device, or this warranty is voided.

This warranty does not cover charges for diagnostic fees or any installation/removal or service charges or shipping of damaged SPD to PSP. Damage claims must be made within 14 days of the occurrence and the damaged unit returned to PSP within 30 days of the occurrence with the original purchase receipts of the items damaged, including the SPD. Returned damaged units require an RMA number to be assigned by PSP Products prior to receiving, as well as a completed PSP claim form. The damaged SPD must be determined to have failed as indicated by diagnostic LEDs and based on PSP's test procedures.

This coverage is secondary to any and all applicable warranties, service contracts and all other insurance or other responsible third parties if the claim is found to be valid, PSP Products will pay up to the deductible amount of the home owners insurance or the cost of the damage, whichever is less. The reimbursement is limited to \$500 per item/system repaired or replaced. All of the above items must be met in order to have a valid claim.

The above coverage applies to the user only and is the exclusive remedy under this warranty, whether based on contract, including negligence, or otherwise. PSP reserves the right to audit damage, site and/or cost of repairs, test grounding system, and may require a notarized proof of loss and proof of homeowners insurance deductible. Claims must be made within 14 days of damage. This warranty does not cover damage associated with sustained over voltages, open neutral, voltage swells, over/under voltage conditions, unstable power, vandalism, theft, normal wear and tear, obsolescence, abuse, unauthorized modification or alteration, misuse, improper installation or catastrophic events including direct or nearby lightning strike. Except as expressly provided by this warranty, PSP disclaims liability for any incidental, indirect, special or consequential damages arising out of the sale or use of any PSP products (including without limitation: lost business profits, loss of data and all freight, mileage, travel time and insurance charges associated with warranty coverage claims). Some states do not allow the exclusion or limitation of incidental or consequential damages, so the above limitation or exclusion may not apply to you. This warranty gives you specific legal rights and you may have other rights which vary from state to state. This warranty is valid in the United States and Canada only.

Caution: Effective surge suppression requires correct wiring. All surge protection devices must be properly grounded for the warranty to be honored.

Warranty Assistance Call 703-687-4057

PSP Products, 8618 Phoenix Drive, Manassas VA 20110

[Register Online at: www.pspproducts.com](http://www.pspproducts.com)

*Transient surge as defined by Institute of Electrical and Electronics Engineers (IEEE)

10.10.24

VA1-50-4XP Product Warranty

Lifetime Product Coverage

PSP will, at its sole discretion, repair or replace any VA1-50-4XP Surge Protection Device (SPD) that is defective or is damaged by a transient electrical spike (including those caused by distant lightning) for the lifetime of the product from the date of installation by the original owner or owner of record of premises.

Down Line Coverage

PSP Products will repair or replace (whichever is less) electrical appliances and electronics that are damaged as a result of a transient surge* greater than the capacity of the SPD, originating at the main utility service entrance. Maximum lifetime coverage per household: \$25,000. Coverage is applicable only if the service entrance SPD (1) was fully functional immediately prior to the claim event, and properly installed per the installation instructions and to NEC guidelines and (2) the SPD received a transient surge greater than its capacity as indicated by the diagnostic LEDs.

External items that are mounted outside of the house are covered under this warranty only if the surge is found to have originated from the main circuit panel due to Service Entrance SPD at end of life, as indicated by diagnostic LEDs. This provision is stated because all exterior wiring is vulnerable to surges caused by nearby lightning strikes. To best protect your exterior items, additional surge protection devices installed at the unit are highly recommended.

Any electronic devices that are connected to phone lines, data lines, coax connections, cable, antennas, satellite receivers, internet, or any other external connections must have a surge protection device for each of the external signals connected to the device, or this warranty is voided.

This warranty does not cover charges for diagnostic fees or any installation/removal or service charges or shipping of damaged SPD to PSP. Damage claims must be made within 14 days of the occurrence and the damaged unit returned to PSP within 30 days of the occurrence with the original purchase receipts of the items damaged, including the SPD. Returned damaged units require an RMA number to be assigned by PSP Products prior to receiving, as well as a completed PSP claim form. The damaged SPD must be determined to have failed as indicated by diagnostic LEDs and based on PSP's test procedures.

This coverage is secondary to any and all applicable warranties, service contracts and all other insurance or other responsible third parties if the claim is found to be valid, PSP Products will pay up to the deductible amount of the home owners insurance or the cost of the damage, whichever is less. The reimbursement is limited to \$500 per item/system repaired or replaced. All of the above items must be met in order to have a valid claim.

The above coverage applies to the user only and is the exclusive remedy under this warranty, whether based on contract, including negligence, or otherwise. PSP reserves the right to audit damage, site and/or cost of repairs, test grounding system, and may require a notarized proof of loss and proof of homeowners insurance deductible. Claims must be made within 14 days of damage. This warranty does not cover damage associated with sustained over voltages, open neutral, voltage swells, over/under voltage conditions, unstable power, vandalism, theft, normal wear and tear, obsolescence, abuse, unauthorized modification or alteration, misuse, improper installation or catastrophic events including direct or nearby lightning strike. Except as expressly provided by this warranty, PSP disclaims liability for any incidental, indirect, special or consequential damages arising out of the sale or use of any PSP products (including without limitation: lost business profits, loss of data and all freight, mileage, travel time and insurance charges associated with warranty coverage claims). Some states do not allow the exclusion or limitation of incidental or consequential damages, so the above limitation or exclusion may not apply to you. This warranty gives you specific legal rights and you may have other rights which vary from state to state. This warranty is valid in the United States and Canada only.

Caution: Effective surge suppression requires correct wiring. All surge protection devices must be properly grounded for the warranty to be honored.

Warranty Assistance Call 703-687-4057

PSP Products, 8618 Phoenix Drive, Manassas VA 20110

[Register Online at: www.pspproducts.com](http://www.pspproducts.com)

*Transient surge as defined by Institute of Electrical and Electronics Engineers (IEEE)

10.10.24